

FEDERAL ENERGY REGULATORY COMMISSION
WASHINGTON, DC 20426

OFFICE OF ENERGY MARKET REGULATION

PJM Interconnection, L.L.C.
Docket No. ER21-2845-000

Issued: October 29, 2021

Wright & Talisman, P.C.
1200 G Street, N.W.
Suite 600
Washington, DC 20005-3898

Attention: David S. Berman, Esq.

Reference: Interim Interconnection Service Agreement – Service Agreement No. 6156

On September 7, 2021, PJM Interconnection, L.L.C. (PJM) submitted an executed Interim Interconnection Service Agreement (Interim ISA) among PJM, Vinton Solar Energy LLC (Vinton), and AEP Ohio Transmission Company, Inc., designated as Original Service Agreement No. 6156 (Vinton Interim ISA).¹ PJM states that it is submitting the Vinton Interim ISA for filing because it contains provisions that do not conform to the form of Interim ISA set forth in Attachment O-1 of the PJM Open Access Transmission Tariff.

Pursuant to the authority delegated to the Director, Division of Electric Power Regulation – East, under 18 C.F.R. § 375.307, the submittal is accepted for filing, effective August 8, 2021, as requested.²

The filing was publicly noticed, with interventions and protests due on or before September 28, 2021. Pursuant to Rule 214 of the Commission's regulations (18 C.F.R. § 385.214), notices of intervention, timely-filed motions to intervene, and any unopposed motions to intervene out-of-time filed before the issuance date of this order are granted. Granting a late intervention at this stage of the proceeding will not disrupt the proceeding or place additional burdens on existing parties. No protests or adverse comments were

¹ PJM Interconnection, L.L.C., FERC FPA Electric Tariff, PJM Service Agreements Tariff, [PJM SA No. 6156, PJM SA No. 6156 among Vinton Solar Energy and AEP, 0.0.0.](#)

² 18 C.F.R. § 35.3(a)(2).

Docket No. ER21-2845-000

- 2 -

filed.

This action does not constitute approval of any service, rate, charge, classification, or any rule, regulation, contract, or practice affecting such rate or service provided for in the filed document(s); nor shall such action be deemed as recognition of any claimed contractual right or obligation affecting or relating to such service or rate, and such action is without prejudice to any findings or orders which have been or may hereafter be made by the Commission in any proceeding now pending or hereafter instituted by or against PJM.

This order constitutes final agency action. Requests for rehearing by the Commission may be filed within 30 days of the date of issuance of this order, pursuant to 18 C.F.R. § 385.713.

Issued by: Kurt M. Longo, Director, Division of Electric Power Regulation – East

Document Content(s)

ER21-2845-000 DLO.docx.....1



1200 G Street, N.W., Suite 600
Washington, D.C. 20005-3898
Phone: 202.393.1200
Fax: 202.393.1240
wrightlaw.com

September 7, 2021

Kimberly D. Bose
Secretary
Federal Energy Regulatory Commission
888 First Street, NE, Room 1A
Washington, DC 20426

*Re: PJM Interconnection, L.L.C., Docket No. ER21- 2845-000
Interim ISA, SA No. 6156; Queue No. AC1-194*

Dear Secretary Bose:

Pursuant to section 205 of the Federal Power Act,¹ part 35 of the Federal Energy Regulatory Commission's ("Commission") regulations,² and Part VI of the PJM Interconnection, L.L.C. ("PJM") Open Access Transmission Tariff ("Tariff"), PJM submits for filing an executed Interim Interconnection Service Agreement ("Interim ISA") among PJM as Transmission Provider, Vinton Solar Energy LLC ("Vinton") as Interconnection Customer, and AEP Ohio Transmission Company, Inc. ("AEP") as Interconnected Transmission Owner, designated as Original Service Agreement No. 6156.³ PJM is filing the Vinton Interim ISA because it contains terms and conditions that do not conform to the form of Interim ISA set forth in Tariff Attachment O-1 ("Interim ISA Form") of the PJM Tariff. The nonconforming provisions are described in more detail in

¹ 16 U.S.C. § 824d.

² 18 C.F.R. part 35.

³ Interim Interconnection Service Agreement By and Among PJM Interconnection, L.L.C. and Vinton Solar Energy LLC and AEP Ohio Transmission Company, Inc. ("Vinton Interim ISA"). PJM, the Interconnection Customer and the Interconnected Transmission Owner are each a "Party" and collectively, the "Parties." A copy of the Vinton Interim ISA is included as Attachment A. Additionally, because the Vinton Interim ISA filed electronically with this transmittal letter contains electronic signatures and not the Parties' original signatures, a copy of the sheet containing the original signatures is included as Attachment B hereto.

Part III and shown in redline format in Attachment C to this transmittal letter. PJM requests an effective date of August 8, 2021, for the Vinton Interim ISA.

I. DESCRIPTION OF THE VINTON INTERIM ISA

The Vinton Interim ISA is associated with PJM Queue No. AC1-194, and facilitates the interconnection of the Vinton Solar Customer Facility to the PJM Transmission System.⁴ The Customer Facility is located in Elk Township, Ohio, and will have a Maximum Facility Output of 125 megawatts.⁵

Section 1.0 lists the Parties to the Interim ISA. Section 4.0(a) states there is a security amount of \$3,536,678 due under the Vinton Interim ISA, and notes that provisions for the billings and payments are set forth in Schedule E to the agreement. Section 7.0(a) requires Vinton to enter into an Interconnection Service Agreement (“ISA”) with AEP when one is tendered, and states that the Vinton Interim ISA will be deemed terminated if Vinton fails to do so (or fails to request dispute resolution or that the agreement be filed with the Commission unexecuted) within the time frames set forth in the Tariff.

Section 9.0 contains provisions related to analyzing and performing a Facilities or System Impact Study, and contains nonconforming language that is described below.

Specifications section 3.0 lists the Network Upgrades and activities subject to this Interim ISA, which include preliminary engineering work and design activities and the procurement of equipment as AEP deems necessary and appropriate for the Attachment Facilities and Network Upgrades listed in the Interim ISA. Specifications section 3.0B states that there are no facilities to be acquired, designed, constructed or installed by

⁴ Vinton Interim ISA, Specifications section 1.0(a).

⁵ *Id.*, Specifications sections 1.0(b)-(c).

Vinton, and Specifications section 4.0 provides the cost breakdown for preliminary design work and other activities to be performed by AEP.

Schedule E contains additional nonconforming billing and payment provisions. In addition, section 10.0 and Specifications section 3.0 contain minor non-substantive provisions that do not conform to the Interim ISA. Each of these nonconforming provisions is addressed below.

II. NONCONFORMING PROVISIONS IN THE VINTON INTERIM ISA

The Vinton Interim ISA contains nonconforming provisions to accommodate the impact of the Vinton project's interconnection on AEP's facilities. These provisions are intended to refine the commercial terms and conditions in the Vinton Interim ISA. Specifically, section 9.0 of the Vinton Interim ISA differs from the Interim ISA Form as follows:

In analyzing and preparing the Facilities Study or the System Impact Study if no Facilities Study is required, and in designing and constructing the Attachment Facilities, Local Upgrades and/or Network Upgrades described in the Specifications attached to this Interim ISA, Transmission Provider, the Interconnected Transmission Owner(s), and any other subcontractors employed by Transmission Provider have had to, and shall have to, rely on information provided by Interconnection Customer and possibly by third parties and may not have control over the accuracy of such information. Accordingly, **NEITHER TRANSMISSION PROVIDER, THE INTERCONNECTED TRANSMISSION OWNER(S), NOR ANY OTHER SUBCONTRACTORS EMPLOYED BY TRANSMISSION PROVIDER OR INTERCONNECTED TRANSMISSION OWNER MAKES ANY WARRANTIES, EXPRESS OR IMPLIED, WHETHER ARISING BY OPERATION OF LAW, COURSE OF PERFORMANCE OR DEALING, CUSTOM, USAGE IN THE TRADE OR PROFESSION, OR OTHERWISE, INCLUDING WITHOUT LIMITATION IMPLIED WARRANTIES OF MERCHANTABILITY AND FITNESS FOR A PARTICULAR PURPOSE, WITH REGARD TO THE ACCURACY, CONTENT, OR CONCLUSIONS OF THE FACILITIES STUDY OR THE SYSTEM IMPACT STUDY IF NO FACILITIES STUDY IS REQUIRED OR OF THE ATTACHMENT FACILITIES, LOCAL UPGRADES AND/OR NETWORK UPGRADES, ~~PROVIDED,~~**

~~HOWEVER, that Transmission Provider warrants that the transmission facilities described in Section 3.0 of the Specifications will be designed, constructed and operated in accordance with Good Utility Practice, as such term is defined in the Operating Agreement~~ OR THE WORK PERFORMED UNDER THIS INTERIM ISA. Interconnection Customer acknowledges that it has not relied on any representations or warranties not specifically set forth herein and that no such representations or warranties have formed the basis of its bargain hereunder.

While nonconforming, the deletion of the phrase “PROVIDED, HOWEVER, that Transmission Provider warrants that the transmission facilities described in Section 3.0 of the Specifications will be designed, constructed and operated in accordance with Good Utility Practice, as such term is defined in the Operating Agreement” and the insertion of the phrase “OR THE WORK PERFORMED UNDER THIS INTERIM ISA” reflects the fact that the activities performed under the Interim ISA are intended to advance completion of the proposed interconnection,⁶ and that because PJM will not own or construct the facilities, it is not responsible for warranting their operation. This change will not harm reliability, and has been agreed to by all parties. The Commission has accepted other Interim ISAs containing similarly modified provisions, and should do the same here.⁷

Similarly, Schedule E contains nonconforming billing and payment provisions for the issuance and payment of invoices and payments to AEP, clarifying the Parties’ obligations in the event of a billing dispute, establishing the amount of interest due, and setting forth suspension and payment provisions. The Commission has accepted other Interim ISAs containing similar provisions, and should do the same here.⁸

⁶ See Vinton Interim ISA, section 3.0; see also Tariff, section 211.

⁷ See *PJM Interconnection, L.L.C.*, Letter Order, Interim Interconnection Service Agreement – Service Agreement No. 6014, Docket No. ER21-1764-000 (June 23, 2021); *PJM Interconnection, L.L.C.*, Letter Order, Interim ISA, SA No. 5848, Docket No. ER21-421-000 (Dec. 18, 2020).

⁸ See supra note 7.

Finally, the Vinton Interim ISA contains two non-substantive provisions that do not conform to the Interim ISA Form. In section 10.0, the word “the” has been added to the first line before the word “acquisition” for clarity. In addition, Specifications section 3.0A of the Interim ISA form was mistakenly labeled as Specifications section 3.0. PJM requests that the Commission accept these changes as they are not material and do not affect the rights or obligations of any Party to the Vinton ISA.

III. WAIVER AND EFFECTIVE DATE

PJM requests an effective date of August 8, 2021, for the Vinton Interim ISA. This requested effective date is appropriate because the Vinton Interim ISA is being filed within 30 days of the commencement of service under the agreement.⁹

IV. DOCUMENTS ENCLOSED

In addition to the transmittal letter, PJM encloses the following with this filing:

1. Attachment A: Vinton Interim ISA, Service Agreement No. 6156;
2. Attachment B: Copy of Sheet Containing Original Signatures to the Vinton Interim ISA; and
3. Attachment C: Redlined Pages Showing the Nonconforming Language in the Vinton Interim ISA.

⁹ See 18 C.F.R. § 35.3(a)(2).

V. CORRESPONDENCE AND COMMUNICATIONS

Correspondence and communications with respect to this filing should be sent to, and PJM requests the Secretary to include on the official service list, the following:¹⁰

Craig Glazer
Vice President – Federal Government Policy
PJM Interconnection, L.L.C.
1200 G Street, NW, Suite 600
Washington, DC 20005
202-423-4743 (phone)
202-393-7741 (fax)
craig.glazer@pjm.com

Wendy B. Warren
David S. Berman
WRIGHT & TALISMAN, P.C.
1200 G Street, NW, Suite 600
Washington, DC 20005-3898
202-393-1200 (phone)
202-393-1240 (fax)
warren@wrightlaw.com
berman@wrightlaw.com

Christopher B. Holt
Assistant General Counsel
PJM Interconnection, L.L.C.
2750 Monroe Blvd,
Audubon, PA 19403
610-666-2368
Christopher.Holt@pjm.com

¹⁰ To the extent necessary, PJM requests waiver of Rule 203(b)(3) of the Commission's Rules of Practice and Procedure, 18 C.F.R. § 385.203(b)(3), to permit all of the persons listed to be placed on the official service list for this proceeding.

VI. SERVICE

PJM has served a copy of this filing on Vinton, AEP, and the affected state regulatory commissions within the PJM Region.

VII. CONCLUSION

For the foregoing reasons, PJM respectfully requests that the Commission accept the Vinton Interim ISA for filing effective August 8, 2021.

Respectfully submitted,

Craig Glazer
Vice President – Federal Government
Policy
PJM Interconnection, L.L.C.
1200 G Street, NW, Suite 600
Washington, DC 20005
202-423-4743 (phone)
202-393-7741(fax)
craig.glazer@pjm.com

/s/ David S. Berman
Wendy B. Warren
David S. Berman
Wright & Talisman, P.C.
1200 G Street, NW, Suite 600
Washington, DC 20005
202-393-1200 (phone)
202-393-1240 (fax)
warren@wrightlaw.com
berman@wrightlaw.com

**Counsel for
PJM Interconnection, L.L.C.**

Christopher B. Holt
Assistant General Counsel
PJM Interconnection, L.L.C.
2750 Monroe Blvd,
Audubon, PA 19403
610-666-2368
Christopher.Holt@pjm.com

Attachment A

Vinton Interim ISA, Service Agreement No. 6156

INTERIM INTERCONNECTION SERVICE AGREEMENT

**By and Among
PJM Interconnection, L.L.C.
and
Vinton Solar Energy LLC
and
AEP Ohio Transmission Company, Inc.
(PJM Queue Position #AC1-194)**

- 1.0 This Interim Interconnection Service Agreement (“Interim ISA”), including the Specifications attached hereto and incorporated herein, is entered into by and among PJM Interconnection, L.L.C. (“Transmission Provider” or “PJM”), Vinton Solar Energy LLC (“Interconnection Customer”), and AEP Ohio Transmission Company, Inc. (“Interconnected Transmission Owner”).
- 2.0 Attached are Specifications for the Customer Facility that Interconnection Customer proposes to interconnect to the Transmission Provider’s Transmission System. Interconnection Customer represents and warrants that, upon completion of their construction, it will own or control the facilities identified in the Specifications attached hereto and made a part hereof. In the event that Interconnection Customer will not own the facilities, Interconnection Customer represents and warrants that it is authorized by the owners of such facilities to enter into this Interim ISA and to represent such control.
- 3.0 In order to advance the completion of its interconnection under the PJM Open Access Transmission Tariff (“Tariff”), Interconnection Customer has requested an Interim ISA and Transmission Provider has determined that Interconnection Customer is eligible under the Tariff to obtain this Interim ISA.
- 4.0 (a) In accord with Section 211 of the Tariff, Interconnection Customer, on or before the effective date of this Interim ISA, shall provide Transmission Provider (for the benefit of the Interconnected Transmission Owner) with a letter of credit from an agreed provider or other form of security reasonably acceptable to Transmission Provider in the amount of \$3,536,678, which amount equals the estimated costs, determined in accordance with Section 217 of the Tariff, of acquiring, designing, constructing and/or installing the facilities described in section 3.0 of the Attached Specifications. Should Interconnection Customer fail to provide such security in the amount or form required, this Interim ISA shall be terminated. Interconnection Customer acknowledges (1) that it will be responsible for the actual costs of the facilities described in the Specifications, whether greater or lesser than the amount of the payment security provided under this section, and (2) that the payment security under this section does not include any additional amounts that it will owe in the event that it executes a final Interconnection Service Agreement, as described in section 7.0(a) below.

(b) Interconnection Customer acknowledges (1) that the purpose of this Interim ISA is to expedite, at Interconnection Customer’s request, the acquisition, design, construction

and/or installation of certain materials and equipment, as described in the Specifications, necessary to interconnect its proposed facilities with Transmission Provider's Transmission System; and (2) that Transmission Provider's Interconnection Studies related to such facilities have not been completed, but that the AC1-194 System Impact Study, dated June 2018 that included Interconnection Customer's project sufficiently demonstrated, in Interconnection Customer's sole opinion, the necessity of facilities additions to the Transmission System to accommodate Interconnection Customer's project to warrant, in Interconnection Customer's sole judgment, its request that the Interconnected Transmission Owner acquire, design, construct and/or install the equipment indicated in the Specifications for use in interconnecting Interconnection Customer's project with the Transmission System.

- 5.0 This Interim ISA shall be effective on the date it is executed by all Interconnection Parties and shall terminate upon the execution and delivery by Interconnection Customer and Transmission Provider of the final Interconnection Service Agreement described in section 7.0(a) below, or on such other date as mutually agreed upon by the parties, unless earlier terminated in accordance with the Tariff.
- 6.0 In addition to the milestones stated in Section 212.5 of the Tariff, during the term of this Interim ISA, Interconnection Customer shall ensure that its generation project meets each of the following development milestones:

NOT APPLICABLE FOR THIS INTERIM ISA

- 7.0 (a) Transmission Provider and the Interconnected Transmission Owner agree to provide for the acquisition, design, construction and/or installation of the facilities identified, and to the extent described, in Section 3.0 of the Specifications in accordance with Part IV of the Tariff, as amended from time to time, and this Interim ISA. Except to the extent for which the Specifications provide for interim interconnection rights for the Interconnection Customer, the parties agree that (1) this Interim ISA shall not provide for or authorize Interconnection Service for the Interconnection Customer, and (2) Interconnection Service will commence only after Interconnection Customer has entered into a final Interconnection Service Agreement with Transmission Provider and the Interconnection Transmission Owner (or, alternatively, has exercised its right to initiate dispute resolution or to have the final Interconnection Service Agreement filed with the FERC unexecuted) after completion of the Facilities Study related to Interconnection Customer's Interconnection Request and otherwise in accordance with the Tariff. The final Interconnection Service Agreement may further provide for construction of, and payment for, transmission facilities additional to those identified in the attached Specifications. Should Interconnection Customer fail to enter into such final Interconnection Service Agreement (or, alternatively, to initiate dispute resolution or request that the agreement be filed with the FERC unexecuted) within the time prescribed by the Tariff, Transmission Provider shall have the right, upon providing written notice to Interconnection Customer, to terminate this Interim ISA.
- (b) In the event that Interconnection Customer decides not to interconnect its proposed facilities, as described in Section 1.0 of the Specifications to the Transmission

System, it shall immediately give Transmission Provider written notice of its determination. Interconnection Customer shall be responsible for the Costs incurred pursuant to this Interim ISA by Transmission Provider and/or by the Interconnected Transmission Owner (1) on or before the date of such notice, and (2) after the date of such notice, if the costs could not reasonably be avoided despite, or were incurred by reason of, Interconnection Customer's determination not to interconnect. Interconnection Customer's liability under the preceding sentence shall include all Cancellation Costs in connection with the acquisition, design, construction and/or installation of the facilities described in section 3.0 of the Specifications. In the event the Interconnected Transmission Owner incurs Cancellation Costs, it shall provide the Transmission Provider, with a copy to the Interconnection Customer, with a written demand for payment and with reasonable documentation of such Cancellation Costs. Within 60 days after the date of Interconnection Customer's notice, Transmission Provider shall provide an accounting of, and the appropriate party shall make any payment to the other that is necessary to resolve, any difference between (i) Interconnection Customer's cost responsibility under this Interim ISA and the Tariff for Costs, including Cancellation Costs, of the facilities described in section 3.0 of the Specifications and (ii) Interconnection Customer's previous payments under this Interim ISA. Notwithstanding the foregoing, however, Transmission Provider shall not be obligated to make any payment that the preceding sentence requires it to make unless and until the Interconnected Transmission Owner has returned to it the portion of Interconnection Customer's previous payments that Transmission Provider must pay under that sentence. This Interim ISA shall be deemed to be terminated upon completion of all payments required under this paragraph (b).

(c) Disposition of the facilities related to this Interim ISA after receipt of Interconnection Customer's notice of its determination not to interconnect shall be decided in accordance with Section 211.1 of the Tariff.

- 8.0 Interconnection Customer agrees to abide by all rules and procedures pertaining to generation in the PJM Region, including but not limited to the rules and procedures concerning the dispatch of generation set forth in the Operating Agreement and the PJM Manuals.
- 9.0 In analyzing and preparing the Facilities Study or the System Impact Study if no Facilities Study is required, and in designing and constructing the Attachment Facilities, Local Upgrades and/or Network Upgrades described in the Specifications attached to this Interim ISA, Transmission Provider, the Interconnected Transmission Owner(s), and any other subcontractors employed by Transmission Provider have had to, and shall have to, rely on information provided by Interconnection Customer and possibly by third parties and may not have control over the accuracy of such information. Accordingly, NEITHER TRANSMISSION PROVIDER, THE INTERCONNECTED TRANSMISSION OWNER(S), NOR ANY OTHER SUBCONTRACTORS EMPLOYED BY TRANSMISSION PROVIDER OR INTERCONNECTED TRANSMISSION OWNER MAKES ANY WARRANTIES, EXPRESS OR IMPLIED, WHETHER ARISING BY OPERATION OF LAW, COURSE OF PERFORMANCE OR DEALING, CUSTOM, USAGE IN THE TRADE OR PROFESSION, OR

OTHERWISE, INCLUDING WITHOUT LIMITATION IMPLIED WARRANTIES OF MERCHANTABILITY AND FITNESS FOR A PARTICULAR PURPOSE, WITH REGARD TO THE ACCURACY, CONTENT, OR CONCLUSIONS OF THE FACILITIES STUDY OR THE SYSTEM IMPACT STUDY IF NO FACILITIES STUDY IS REQUIRED OR OF THE ATTACHMENT FACILITIES, LOCAL UPGRADES AND/OR NETWORK UPGRADES OR THE WORK PERFORMED UNDER THIS INTERIM ISA. Interconnection Customer acknowledges that it has not relied on any representations or warranties not specifically set forth herein and that no such representations or warranties have formed the basis of its bargain hereunder.

- 10.0 Within 120 days after the Interconnected Transmission Owner completes the acquisition, design, construction and/or installation of the facilities described in Section 3.0 of the Specifications, Transmission Provider shall provide Interconnection Customer with an accounting of, and the appropriate party shall make any payment to the other that is necessary to resolve, any difference between (a) Interconnection Customer's responsibility under this Interim ISA and the Tariff for the actual cost of such equipment, and (b) Interconnection Customer's previous aggregate payments to Transmission Provider and the Interconnected Transmission Owner hereunder. Notwithstanding the foregoing, however, Transmission Provider shall not be obligated to make any payment that the preceding sentence requires it to make unless and until the Interconnected Transmission Owner has returned to it the portion of Interconnection Customer's previous payments that Transmission Provider must pay under that sentence.
- 11.0 No third party beneficiary rights are created under this Interim ISA, provided, however, that payment obligations imposed on Interconnection Customer hereunder are agreed and acknowledged to be for the benefit of the Interconnected Transmission Owner actually performing the services associated with the interconnection of the Generating Facilities and any associated upgrades of other facilities.
- 12.0 No waiver by either party of one or more defaults by the other in performance of any of the provisions of this Interim ISA shall operate or be construed as a waiver of any other or further default or defaults, whether of a like or different character.
- 13.0 This Interim ISA or any part thereof, may not be amended, modified, assigned, or waived other than by a writing signed by all parties hereto.
- 14.0 This Interim ISA shall be binding upon the parties hereto, their heirs, executors, administrators, successors, and assigns.
- 15.0 This Interim ISA shall not be construed as an application for service under Part II or Part III of the Tariff.
- 16.0 Any notice or request made to or by either Party regarding this Interim ISA shall be made to the representative of the other Party as indicated below.

Transmission Provider

PJM Interconnection, L.L.C.
2750 Monroe Blvd.
Audubon, PA 19403

Interconnection Customer

Vinton Solar Energy LLC
General Counsel
One South Wacker Drive, Suite 1800
Chicago, IL 60606
GeneralCounsel@invenergy.com
Interconnection-notices@invenergy.com

Interconnected Transmission Owner

AEP Ohio Transmission Company, Inc.
c/o Robert Pennybaker, Director – System Interconnections
American Electric Power Service Corporation
212 E 6th St. – 4th Floor
Tulsa, OK 74119
rlpennybaker@aep.com

Cc: John W. Seidensticker, Senior Counsel
American Electric Power Service Corporation
1 Riverside Plaza – 29th Floor
Columbus, OH 43215
jwseidensticker@aep.com

- 17.0 All portions of the Tariff and the Operating Agreement pertinent to the subject of this Interim ISA are incorporated herein and made a part hereof.
- 18.0 This Interim ISA is entered into pursuant to Part IV of the Tariff.
- 19.0 Neither party shall be liable for consequential, incidental, special, punitive, exemplary or indirect damages, lost profits or other business interruption damages, by statute, in tort or contract, under any indemnity provision or otherwise with respect to any claim, controversy or dispute arising under this Interim ISA.
- 20.0 Addendum of Interconnection Customer’s Agreement to Conform with IRS Safe Harbor Provisions for Non-Taxable Status. To the extent required, in accordance with Section 20.1, Schedule A to this Interim ISA shall set forth the Interconnection Customer’s agreement to conform with the IRS safe harbor provisions for non-taxable status.
- 20.1 Tax Liability
 - 20.1.1 Safe Harbor Provisions:

This Section 20.1.1 is applicable only to Generation Interconnection Customers. Provided that Interconnection Customer agrees to conform to all requirements of the Internal Revenue Service (“IRS”) (e.g., the “safe harbor” provisions of IRS Notices 2001-82 and 88-129) that would confer nontaxable status on some or all of the transfer of property, including money, by Interconnection Customer to the Interconnected Transmission Owner for payment of the Costs of construction of the Transmission Owner Interconnection Facilities, the Interconnected Transmission Owner, based on such agreement and on current law, shall treat such transfer of property to it as nontaxable income and, except as provided in Section 20.1.2 below, shall not include income taxes in the Costs of Transmission Owner Interconnection Facilities that are payable by Interconnection Customer under the Interim Interconnection Service Agreement, the Interconnection Service Agreement or the Interconnection Construction Service Agreement. Interconnection Customer shall document its agreement to conform to IRS requirements for such non-taxable status in the Interconnection Service Agreement, the Interconnection Construction Service Agreement, and/or the Interim Interconnection Service Agreement.

20.1.2 Tax Indemnity:

Interconnection Customer shall indemnify the Interconnected Transmission Owner for any costs that Interconnected Transmission Owner incurs in the event that the IRS and/or a state department of revenue (State) determines that the property, including money, transferred by Interconnection Customer to the Interconnected Transmission Owner with respect to the construction of the Transmission Owner Interconnection Facilities is taxable income to the Interconnected Transmission Owner. Interconnection Customer shall pay to the Interconnected Transmission Owner, on demand, the amount of any income taxes that the IRS or a State assesses to the Interconnected Transmission Owner in connection with such transfer of property and/or money, plus any applicable interest and/or penalty charged to the Interconnected Transmission Owner. In the event that the Interconnected Transmission Owner chooses to contest such assessment, either at the request of Interconnection Customer or on its own behalf, and prevails in reducing or eliminating the tax, interest and/or penalty assessed against it, the Interconnected Transmission Owner shall refund to Interconnection Customer the excess of its demand payment made to the Interconnected Transmission Owner over the amount of the tax, interest and penalty for which the Interconnected Transmission Owner is finally determined to be liable. Interconnection Customer’s tax indemnification obligation under this section shall survive any termination of the Interim Interconnection Service Agreement or Interconnection Construction Service Agreement.

20.1.3 Taxes Other Than Income Taxes:

Upon the timely request by Interconnection Customer, and at Interconnection Customer’s sole expense, the Interconnected Transmission Owner shall appeal, protest, seek abatement of, or otherwise contest any tax (other than federal or state income tax) asserted or assessed against the Interconnected Transmission Owner for which Interconnection Customer may be required to reimburse Transmission Provider under the terms of this Interim Interconnection Service Agreement or Part VI of the Tariff. Interconnection Customer shall pay to the Interconnected

Transmission Owner on a periodic basis, as invoiced by the Interconnected Transmission Owner, the Interconnected Transmission Owner's documented reasonable costs of prosecuting such appeal, protest, abatement, or other contest. Interconnection Customer and the Interconnected Transmission Owner shall cooperate in good faith with respect to any such contest. Unless the payment of such taxes is a prerequisite to an appeal or abatement or cannot be deferred, no amount shall be payable by Interconnection Customer to the Interconnected Transmission Owner for such contested taxes until they are assessed by a final, non-appealable order by any court or agency of competent jurisdiction. In the event that a tax payment is withheld and ultimately due and payable after appeal, Interconnection Customer will be responsible for all taxes, interest and penalties, other than penalties attributable to any delay caused by the Interconnected Transmission Owner.

20.1.4 Income Tax Gross-Up

20.1.4.1 Additional Security:

In the event that Interconnection Customer does not provide the safe harbor documentation required under Section 20.1.1 prior to execution of this Interim Interconnection Service Agreement, within 15 days after such execution, Transmission Provider shall notify Interconnection Customer in writing of the amount of additional Security that Interconnection Customer must provide. The amount of Security that a Transmission Interconnection Customer must provide initially pursuant to this Interim Interconnection Service Agreement shall include any amounts described as additional Security under this Section 20.1.4 regarding income tax gross-up.

20.1.4.2 Amount:

The required additional Security shall be in an amount equal to the amount necessary to gross up fully for currently applicable federal and state income taxes the estimated Costs of Local Upgrades and Network Upgrades for which Interconnection Customer previously provided Security. Accordingly, the additional Security shall equal the amount necessary to increase the total Security provided to the amount that would be sufficient to permit the Interconnected Transmission Owner to receive and retain, after the payment of all applicable income taxes ("Current Taxes") and taking into account the present value of future tax deductions for depreciation that would be available as a result of the anticipated payments or property transfers (the "Present Value Depreciation Amount"), an amount equal to the estimated Costs of Local Upgrades and Network Upgrades for which Interconnection Customer is responsible under the Interconnection Service Agreement. For this purpose, Current Taxes shall be computed based on the composite federal and state income tax rates applicable to the Interconnected Transmission Owner at the time the additional Security is received, determined using the highest marginal rates in effect at that time (the "Current Tax Rate"), and (ii) the Present Value Depreciation Amount shall be computed by discounting the Interconnected Transmission Owner's anticipated tax depreciation deductions associated with such payments or property transfers by its current weighted average cost of capital.

20.1.4.3 Time for Payment:

Interconnection Customer must provide the additional Security, in a form and with terms as required by Sections 212.4 of the Tariff, within 15 days after its receipt of Transmission Provider's notice under this section. The requirement for additional Security under this section shall be treated as a milestone included in the Interconnection Service Agreement pursuant to Section 212.5 of the Tariff.

20.1.5 Tax Status:

Each Party shall cooperate with the other to maintain the other Party's tax status. Nothing in this Interim Interconnection Service Agreement or the Tariff is intended to adversely affect any Interconnected Transmission Owner's tax exempt status with respect to the issuance of bonds including, but not limited to, local furnishing bonds.

21.0 Addendum of Interconnection Requirement for all Wind or Non-synchronous Generation Facilities. To the extent required, Schedule B to this Interim ISA sets forth interconnection requirements for all wind or non-synchronous generation facilities and is hereby incorporated by reference and made a part of this Interim ISA.

22.0 Infrastructure security of electric system equipment and operations and control hardware and software is essential to ensure day-to-day reliability and operational security. All Transmission Providers, Interconnected Transmission Owners, market participants, and Interconnection Customers interconnected with electric systems are to comply with the recommendations offered by the President's Critical Infrastructure Protection Board and best practice recommendations from the electric reliability authority. All public utilities are expected to meet basic standards for electric system infrastructure and operational security, including physical, operational, and cyber-security practices.

IN WITNESS WHEREOF, Transmission Provider, Interconnection Customer and Interconnected Transmission Owner have caused this Interim ISA to be executed by their respective authorized officials.

(PJM Queue Position #AC1-194)

Transmission Provider: PJM Interconnection, L.L.C.

| | | |
|--------------------------------|--|-----------------|
| By: <u>/s/ Jason Shoemaker</u> | <u>Manager, Interconnection Projects</u> | <u>8/8/2021</u> |
| Name | Title | Date |

Printed name of signer: Jason Shoemaker

Interconnection Customer: **Vinton Solar Energy LLC**

| | | |
|-------------------------------|-----------------------|------------------|
| By: <u>/s/ Michael Kaplan</u> | <u>Vice President</u> | <u>6/22/2021</u> |
| Name | Title | Date |

Printed name of signer: Michael Kaplan

Interconnected Transmission Owner: **AEP Ohio Transmission Company, Inc.**

| | | |
|----------------------------------|-----------------------|------------------|
| By: <u>/s/ Robert W. Bradish</u> | <u>Vice President</u> | <u>7/28/2021</u> |
| Name | Title | Date |

Printed name of signer: Robert W. Bradish

**SPECIFICATIONS FOR
INTERIM INTERCONNECTION SERVICE AGREEMENT**

**By and Among
PJM INTERCONNECTION, L.L.C.**

**And
Vinton Solar Energy LLC**

**And
AEP Ohio Transmission Company, Inc.**

(PJM Queue Position #AC1-194)

1.0 Description of Customer Facility to be interconnected with the Transmission System in the PJM Region:

a. Name of Customer Facility:

Vinton Solar

b. Location of Customer Facility:

Morgan and Barleon Rds., Elk Township, OH 45651

c. Size in megawatts of Customer Facility:

For Generation Interconnection Customer:

Maximum Facility Output of 125 MW

2.0 Interconnection Rights: Interconnection Customer shall obtain Capacity Interconnection Rights in accordance with Subpart C of Part VI of the Tariff at the location specified in section 1.0b upon its execution of the final Interconnection Service Agreement described in section 7.0(a) of this Interim ISA.

3.0 Facilities to be acquired, designed, constructed and/or installed by the Interconnected Transmission Owner under this Interim ISA:

Perform preliminary engineering and design activities and commence procurement of equipment as Interconnected Transmission Owner deems necessary and appropriate for the following components of the AC1-194 project:

Attachment Facilities:

a) 138 kV Revenue Metering. Network Upgrade Number n5676.

Direct Connection Network Upgrades:

- a) Expand the Elk 138 kV substation: Install two (2) 138 kV buses, and install three (3) additional 138 kV circuit breakers. Installation of associated protection and control equipment, 138 kV line risers and SCADA. Network Upgrade Number n5674.

Non-Direct Connection Network Upgrades:

- a) Upgrade line protections & controls at the Poston 138 kV substation. Network Upgrade Number n5677.
- b) Upgrade line protections & controls at the Corwin 138 kV substation. Network Upgrade Number n5678.
- c) Elk-Poston 138 kV circuit cut into Elk 138 kV. Network Upgrade Number n5675

3.0.B Facilities to be acquired, designed, constructed and/or installed by the Interconnection Customer under this Interim ISA:
None.

4.0 Interconnection Customer shall be subject to the charges detailed below:

4.1 Attachment Facilities Charge: \$122,959

4.2 Local Upgrades Charge: \$0

4.3 Network Upgrades Charge: \$3,413,719

4.4 Cost Breakdown:

| | |
|-------------|-------------------|
| \$176,858 | Direct Labor |
| \$2,688,443 | Direct Material |
| \$47,080 | Indirect Labor |
| \$624,297 | Indirect Material |
| | |
| \$3,536,678 | Total |

SCHEDULES:

SCHEDULE A – INTERCONNECTION CUSTOMER’S AGREEMENT TO CONFORM WITH IRS SAFE HARBOR PROVISIONS FOR NON-TAXABLE STATUS

SCHEDULE B - INTERCONNECTION REQUIREMENTS FOR A WIND GENERATION FACILITY

SCHEDULE C - CUSTOMER FACILITY LOCATION/SITE PLAN

SCHEDULE D - SINGLE-LINE DIAGRAM

SCHEDULE E – NON-STANDARD TERMS AND CONDITIONS

SCHEDULE A

INTERCONNECTION CUSTOMER'S AGREEMENT TO CONFORM WITH IRS SAFE HARBOR PROVISIONS FOR NON-TAXABLE STATUS

As provided in Section 20.1 of this Interim ISA and subject to the requirements thereof, Interconnection Customer represents that it meets all qualifications and requirements as set forth in Section 118(a) and 118(b) of the Internal Revenue Code of 1986, as amended and interpreted by Notice 2016-36, 2016-25 I.R.B. (6/20/2016) (the "IRS Notice"). Interconnection Customer agrees to conform with all requirements of the safe harbor provisions specified in the IRS Notice, as they may be amended, as required to confer non-taxable status on some or all of the transfer of property, including money, by Interconnection Customer to Interconnected Transmission Owner with respect to the payment of the Costs of construction and installation of the Transmission Owner Interconnection Facilities specified in this Interim ISA.

Nothing in Interconnection Customer's agreement pursuant to this Schedule A shall change Interconnection Customer's indemnification obligations under Section 20.1 of this Interim ISA.

SCHEDULE B

INTERCONNECTION REQUIREMENTS FOR ALL WIND AND NON-SYNCHRONOUS GENERATION FACILITIES

A. Voltage Ride Through Requirements

The Customer Facility shall be designed to remain in service (not trip) for voltages and times as specified for the Eastern Interconnection in Attachment 1 of NERC Reliability Standard PRC-024-1, and successor Reliability Standards, for both high and low voltage conditions, irrespective of generator size, subject to the permissive trip exceptions established in PRC-024-1 (and successor Reliability Standards).

B. Frequency Ride Through Requirements

The Customer Facility shall be designed to remain in service (not trip) for frequencies and times as specified in Attachment 2 of NERC Reliability Standard PRC-024-1, and successor Reliability Standards, for both high and low frequency condition, irrespective of generator size, subject to the permissive trip exceptions established in PRC-024-1 (and successor Reliability Standards).

C. Supervisory Control and Data Acquisition (SCADA) Capability

The wind or non-synchronous generation facility shall provide SCADA capability to transmit data and receive instructions from the Transmission Provider to protect system reliability. The Transmission Provider and the wind or non-synchronous generation facility Interconnection Customer shall determine what SCADA information is essential for the proposed wind or non-synchronous generation facility, taking into account the size of the facility and its characteristics, location, and importance in maintaining generation resource adequacy and transmission system reliability in its area.

D. Meteorological Data Reporting Requirement (Applicable to wind generation facilities only)

The wind generation facility shall, at a minimum, be required to provide the Transmission Provider with site-specific meteorological data including:

- Temperature (degrees Fahrenheit)
- Wind speed (meters/second)
- Wind direction (degrees from True North)
- Atmosphere pressure (hectopascals)
- Forced outage data (wind turbine and MW unavailability)

The Transmission Provider and Interconnection Customer may mutually agree to any additional meteorological data that are required for the development and deployment of a power production forecast. All requirements for meteorological and forced outage data must be commensurate with the power production forecasting employed by the

Transmission Provider. Such additional mutually agreed upon requirements for meteorological and forced outage data are set forth below:

NOT APPLICABLE FOR THIS INTERIM ISA

**SCHEDULE C
CUSTOMER FACILITY LOCATION/SITE PLAN**

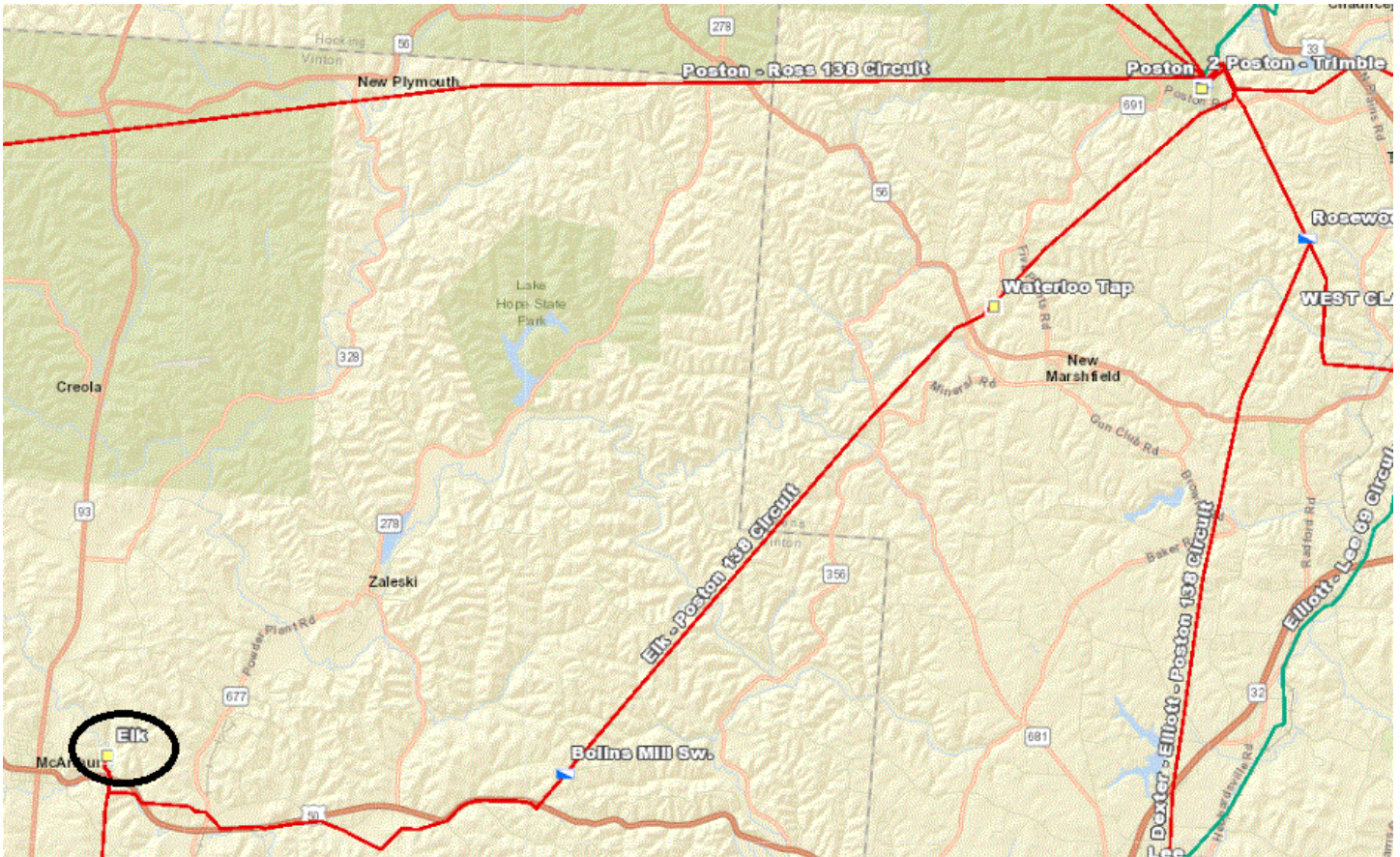

SCHEDULE D SINGLE-LINE DIAGRAM



**AC1-194 Point of Interconnection Elk 138 kV
Single-line Diagram (Remote stations not completely shown)**

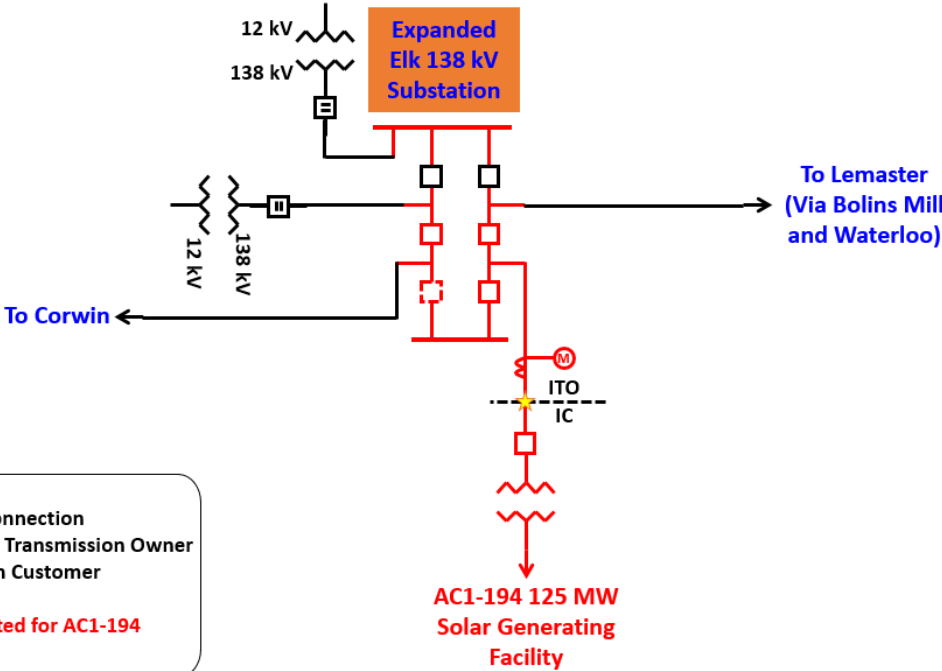

- | Legend | |
|--------|-----------------------------------|
| ★ | Point of Interconnection |
| ITO | Interconnected Transmission Owner |
| IC | Interconnection Customer |
| — | Existing |
| — | To be Constructed for AC1-194 |
| - - | Future Facility |

SCHEDULE E

NON-STANDARD TERMS AND CONDITIONS

Additional Provisions for Billings and Payments

The following provisions shall apply with respect to charges for the Costs of the Interconnected Transmission Owner for which the Interconnection Customer is responsible.

Transmission Provider shall invoice Interconnection Customer on behalf of the Interconnected Transmission Owner, for the Interconnected Transmission Owner's expected Costs during the next three months. Upon receipt of each of Interconnection Customer's payments of such invoices, Transmission Provider shall reimburse the Interconnected Transmission Owner. Interconnection Customer shall pay each invoice received from Transmission Provider within twenty (20) days after receipt thereof. Interest on any unpaid, delinquent amounts shall be calculated in accordance with the methodology specified for interest on refunds in the FERC's regulations at 18 C.F.R. Section 35.19a(a)(2)(iii) and shall apply from the due date of the bill to the date of payment. If Interconnection Customer fails to pay any invoice when and as due, Transmission Provider or Interconnected Transmission Owner can provide notice of such failure to Interconnection Customer and the other party, and Interconnection Customer shall pay the amounts due within five (5) days from the receipt of such notice. Subject to obtaining any necessary authorizations from FERC, if Interconnection Customer fails to make payment within five (5) days from the receipt of such notice, Transmission Provider and Interconnected Transmission Owner shall each have the right to suspend performance hereunder. If Interconnection Customer fails to make payment within fifteen (15) days from the receipt of such notice, Transmission Provider and Interconnected Transmission Owner shall each have the right to terminate this Agreement, or exercise such other rights and remedies, as each may have in equity or at law.

Attachment B

Copy of Sheet Containing Original Signatures to the Vinton Interim ISA

IN WITNESS WHEREOF, Transmission Provider, Interconnection Customer and Interconnected Transmission Owner have caused this Interim ISA to be executed by their respective authorized officials.

(PJM Queue Position #AC1-194)

Transmission Provider: PJM Interconnection, L.L.C.

By: Jason Shoemaker Manager, Interconnection Projects 8/8/2021
Name Title Date

Printed name of signer: Jason Shoemaker

Interconnection Customer: **Vinton Solar Energy LLC**

By: Michael Kaplan Vice President 6/22/2021
Name Title Date

Printed name of signer: Michael Kaplan

Interconnected Transmission Owner: **AEP Ohio Transmission Company, Inc.**

By: Robert W. Bradish Vice President 7/28/2021
Name Title Date

Printed name of signer: Robert W. Bradish

Attachment C

Redlined Pages Showing the Nonconforming Language in the Vinton Interim ISA

pursuant to this Interim ISA by Transmission Provider and/or by the Interconnected Transmission Owner (1) on or before the date of such notice, and (2) after the date of such notice, if the costs could not reasonably be avoided despite, or were incurred by reason of, Interconnection Customer's determination not to interconnect. Interconnection Customer's liability under the preceding sentence shall include all Cancellation Costs in connection with the acquisition, design, construction and/or installation of the facilities described in section 3.0 of the Specifications. In the event the Interconnected Transmission Owner incurs Cancellation Costs, it shall provide the Transmission Provider, with a copy to the Interconnection Customer, with a written demand for payment and with reasonable documentation of such Cancellation Costs. Within 60 days after the date of Interconnection Customer's notice, Transmission Provider shall provide an accounting of, and the appropriate party shall make any payment to the other that is necessary to resolve, any difference between (i) Interconnection Customer's cost responsibility under this Interim ISA and the Tariff for Costs, including Cancellation Costs, of the facilities described in section 3.0 of the Specifications and (ii) Interconnection Customer's previous payments under this Interim ISA. Notwithstanding the foregoing, however, Transmission Provider shall not be obligated to make any payment that the preceding sentence requires it to make unless and until the Interconnected Transmission Owner has returned to it the portion of Interconnection Customer's previous payments that Transmission Provider must pay under that sentence. This Interim ISA shall be deemed to be terminated upon completion of all payments required under this paragraph (b).

(c) Disposition of the facilities related to this Interim ISA after receipt of Interconnection Customer's notice of its determination not to interconnect shall be decided in accordance with Section 211.1 of the Tariff.

8.0 Interconnection Customer agrees to abide by all rules and procedures pertaining to generation in the PJM Region, including but not limited to the rules and procedures concerning the dispatch of generation set forth in the Operating Agreement and the PJM Manuals.

9.0 In analyzing and preparing the Facilities Study or the System Impact Study if no Facilities Study is required, and in designing and constructing the Attachment Facilities, Local Upgrades and/or Network Upgrades described in the Specifications attached to this Interim ISA, Transmission Provider, the Interconnected Transmission Owner(s), and any other subcontractors employed by Transmission Provider have had to, and shall have to, rely on information provided by Interconnection Customer and possibly by third parties and may not have control over the accuracy of such information. Accordingly, NEITHER TRANSMISSION PROVIDER, THE INTERCONNECTED TRANSMISSION OWNER(S), NOR ANY OTHER SUBCONTRACTORS EMPLOYED BY TRANSMISSION PROVIDER OR INTERCONNECTED TRANSMISSION OWNER MAKES ANY WARRANTIES, EXPRESS OR IMPLIED, WHETHER ARISING BY OPERATION OF LAW, COURSE OF PERFORMANCE OR DEALING, CUSTOM, USAGE IN THE TRADE OR PROFESSION, OR OTHERWISE, INCLUDING WITHOUT LIMITATION IMPLIED WARRANTIES OF MERCHANTABILITY AND FITNESS FOR A PARTICULAR PURPOSE, WITH REGARD TO THE ACCURACY,

CONTENT, OR CONCLUSIONS OF THE FACILITIES STUDY OR THE SYSTEM IMPACT STUDY IF NO FACILITIES STUDY IS REQUIRED OR OF THE ATTACHMENT FACILITIES, LOCAL UPGRADES AND/OR NETWORK UPGRADES UPGRADES, ~~HOWEVER, that Transmission Provider warrants that the transmission facilities described in Section 3.0 of the Specifications will be designed, constructed and operated in accordance with Good Utility Practice, as such term is defined in the Operating Agreement~~ **OR THE WORK PERFORMED UNDER THIS INTERIM ISA.** Interconnection Customer acknowledges that it has not relied on any representations or warranties not specifically set forth herein and that no such representations or warranties have formed the basis of its bargain hereunder.

- 10.0 Within 120 days after the Interconnected Transmission Owner completes the acquisition, design, construction and/or installation of the facilities described in Section 3.0 of the Specifications, Transmission Provider shall provide Interconnection Customer with an accounting of, and the appropriate party shall make any payment to the other that is necessary to resolve, any difference between (a) Interconnection Customer's responsibility under this Interim ISA and the Tariff for the actual cost of such equipment, and (b) Interconnection Customer's previous aggregate payments to Transmission Provider and the Interconnected Transmission Owner hereunder. Notwithstanding the foregoing, however, Transmission Provider shall not be obligated to make any payment that the preceding sentence requires it to make unless and until the Interconnected Transmission Owner has returned to it the portion of Interconnection Customer's previous payments that Transmission Provider must pay under that sentence.
- 11.0 No third party beneficiary rights are created under this Interim ISA, provided, however, that payment obligations imposed on Interconnection Customer hereunder are agreed and acknowledged to be for the benefit of the Interconnected Transmission Owner actually performing the services associated with the interconnection of the Generating Facilities and any associated upgrades of other facilities.
- 12.0 No waiver by either party of one or more defaults by the other in performance of any of the provisions of this Interim ISA shall operate or be construed as a waiver of any other or further default or defaults, whether of a like or different character.
- 13.0 This Interim ISA or any part thereof, may not be amended, modified, assigned, or waived other than by a writing signed by all parties hereto.
- 14.0 This Interim ISA shall be binding upon the parties hereto, their heirs, executors, administrators, successors, and assigns.
- 15.0 This Interim ISA shall not be construed as an application for service under Part II or Part III of the Tariff.
- 16.0 Any notice or request made to or by either Party regarding this Interim ISA shall be made to the representative of the other Party as indicated below.

**SPECIFICATIONS FOR
INTERIM INTERCONNECTION SERVICE AGREEMENT**

**By and Among
PJM INTERCONNECTION, L.L.C.**

**And
Vinton Solar Energy LLC**

**And
AEP Ohio Transmission Company, Inc.**

(PJM Queue Position #AC1-194)

1.0 Description of Customer Facility to be interconnected with the Transmission System in the PJM Region:

a. Name of Customer Facility:

Vinton Solar

b. Location of Customer Facility:

Morgan and Barleon Rds., Elk Township, OH 45651

c. Size in megawatts of Customer Facility:

For Generation Interconnection Customer:

Maximum Facility Output of 125 MW

2.0 Interconnection Rights: Interconnection Customer shall obtain Capacity Interconnection Rights in accordance with Subpart C of Part VI of the Tariff at the location specified in section 1.0b upon its execution of the final Interconnection Service Agreement described in section 7.0(a) of this Interim ISA.

3.0~~A~~ Facilities to be acquired, designed, constructed and/or installed by the Interconnected Transmission Owner under this Interim ISA:

Perform preliminary engineering and design activities and commence procurement of equipment as Interconnected Transmission Owner deems necessary and appropriate for the following components of the AC1-194 project:

Attachment Facilities:

a) 138 kV Revenue Metering. Network Upgrade Number n5676.

Direct Connection Network Upgrades:

SCHEDULE E

NON-STANDARD TERMS AND CONDITIONS

Additional Provisions for Billings and Payments

The following provisions shall apply with respect to charges for the Costs of the Interconnected Transmission Owner for which the Interconnection Customer is responsible.

Transmission Provider shall invoice Interconnection Customer on behalf of the Interconnected Transmission Owner, for the Interconnected Transmission Owner's expected Costs during the next three months. Upon receipt of each of Interconnection Customer's payments of such invoices, Transmission Provider shall reimburse the Interconnected Transmission Owner. Interconnection Customer shall pay each invoice received from Transmission Provider within twenty (20) days after receipt thereof. Interest on any unpaid, delinquent amounts shall be calculated in accordance with the methodology specified for interest on refunds in the FERC's regulations at 18 C.F.R. Section 35.19a(a)(2)(iii) and shall apply from the due date of the bill to the date of payment. If Interconnection Customer fails to pay any invoice when and as due, Transmission Provider or Interconnected Transmission Owner can provide notice of such failure to Interconnection Customer and the other party, and Interconnection Customer shall pay the amounts due within five (5) days from the receipt of such notice. Subject to obtaining any necessary authorizations from FERC, if Interconnection Customer fails to make payment within five (5) days from the receipt of such notice, Transmission Provider and Interconnected Transmission Owner shall each have the right to suspend performance hereunder. If Interconnection Customer fails to make payment within fifteen (15) days from the receipt of such notice, Transmission Provider and Interconnected Transmission Owner shall each have the right to terminate this Agreement, or exercise such other rights and remedies, as each may have in equity or at law.