



Public Distribution Microgrid Business Rules

Natalie Tacka
Engineer, Applied Innovation

Market & Reliability Committee
April 21, 2021



Background & Endorsement Timeline

- Single package on Public Distribution Microgrid Business Rules through DER & Inverter-Based Resources Subcommittee
- Manual updates made to initial MRC first read

Stakeholder Body	NOV 2020	DEC 2020	APR 2021	MAY 2021
DIRS	11/02: review draft language			
SOS	11/02: first read	11/30: endorsement		
OC	11/06: first read	12/03: endorsement		
MIC	11/05: first read	12/02: endorsement		
MRC		12/17: first read	4/21: first read	5/26: endorsement

Stakeholder Feedback Discussions

- A **microgrid** is a system of generation + load that can run on-grid or off-grid.
- A Public Distribution Microgrid is **operated by the distribution utility**, uses **public utility distribution wires** to serve load during islanding, and **does not include** NERC Bulk Electric System Facilities or PJM Transmission Facilities.
- A Public Distribution Microgrid Generator is a **PJM wholesale generator** capable of operating while connected to or islanded from the broader grid.
- The Electric Distribution Company, in coordination with the Public Distribution Microgrid Operator and affected Electric Distributor(s) determines **whether or not the PDM load is wholesale load when islanded**.

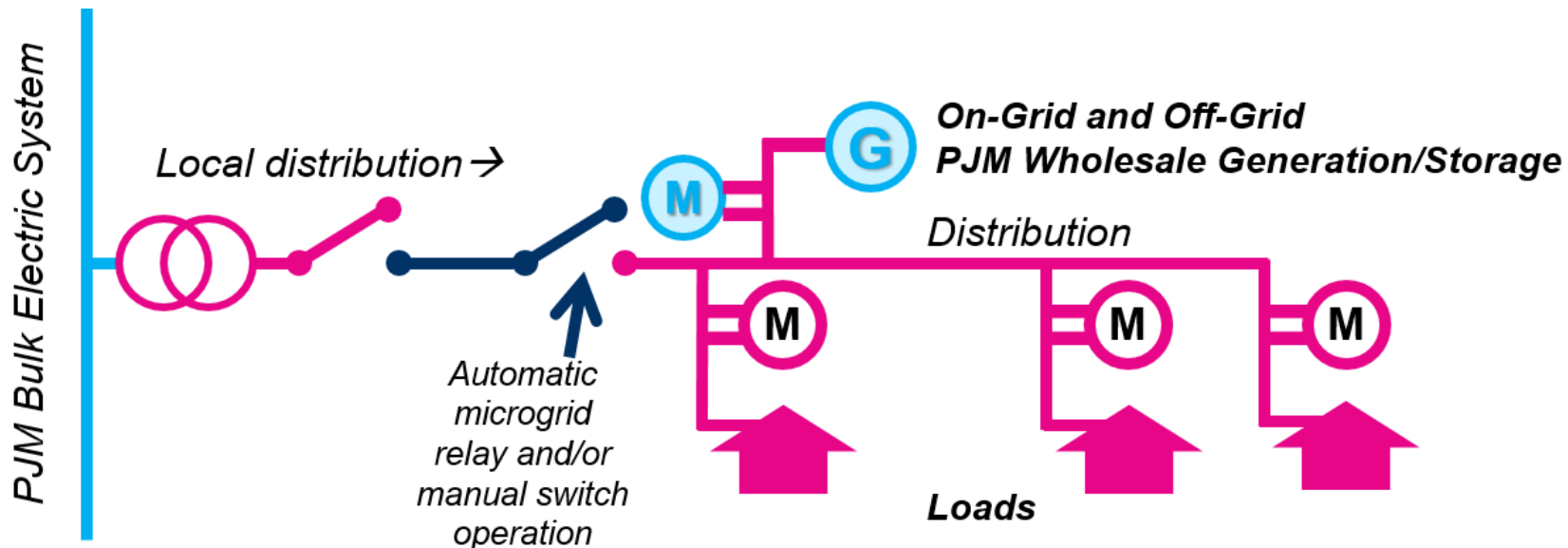

Manual Language	Components
M-14D , Section 4.2.2	<ul style="list-style-type: none"> • New table row for telemetry requirements
M-14D , Appendix B: Public Distribution Microgrid Business Rules	<ul style="list-style-type: none"> • Definitions • Provisions for operations in island mode <ul style="list-style-type: none"> • Telemetry requirements • Notification requirements • Outage reporting
M-14D , Appendix C: Voluntary Guideline on Public Distribution Microgrid Operations	<ul style="list-style-type: none"> • Reasons islanding should and should not occur
M-11 , Section 2.3.3.4	<ul style="list-style-type: none"> • Provisions for reflecting islanded condition in resource availability for Energy and Ancillary Services
M-18 , Section 8.4A	<ul style="list-style-type: none"> • Clarification for PAI treatment of PDM Generators that are Generation Capacity Resources

- Updates to Public Distribution Microgrid Definition to clarify the scope and establishment of a PDM.
- Language specifying coordination and consent between the applicable fully-metered Electric Distribution Company, affected Electric Distributor(s), and Public Distribution Microgrid Operator in determining whether or not the PDM load is reported to PJM as wholesale load when the PDM is islanded.
- Telemetry & notification clarifications considering additional data flow scenarios between PDM Operator and PDM Generator.
- Related clean-up

DIRS Facilitator:
Scott Baker, scott.baker@pjm.com

DIRS Secretary:
Hamad Ahmed, hamad.ahmed@pjm.com

Presenter:
Natalie Tacka, natalie.tacka@pjm.com

Public Distribution Microgrids



Member Hotline

(610) 666 – 8980

(866) 400 – 8980

custsvc@pjm.com



Appendix: Manual Updates to Dec 2020 First Read



M-14D, Appendix B: Public Distribution Microgrid Business Rules

Definitions

A Microgrid is a pre-determined set of ~~Generating Facilities~~generators and load that can operate both while connected to and while islanded (i.e., isolated) from the broader grid. A Microgrid must include load, one or more ~~Generating Facilities~~generators, one or more switches for isolating and connecting to the broader grid, and a microgrid controller. ~~A Microgrid could include public utility distribution facilities.~~

~~A Microgrid shall be considered a~~ Public Distribution Microgrid (“PDM”) ~~shall mean a Microgrid that if it~~ includes a PJM Generating Facility that is capable of generating while both connected to and while islanded from the broader grid, and which also includes ~~dual-use~~ utility distribution facilities. A ~~Public Distribution~~ Microgrid ~~shall is~~ not ~~considered a Public Distribution Microgrid if the energized portion of the islanded Microgrid~~ includes any NERC Bulk Electric System facilities or any PJM Transmission Facilities.; ~~and A Public Distribution Microgrid is operated by an Electric Distributor or third party operator designated by the Electric Distributor. The relevant Public Distribution Microgrid Operator, as defined below, establishes the Public Distribution Microgrid and defines the set of Generating Facilities, distribution facilities, and load that comprise it.~~

Public Distribution Microgrid Operator shall mean: (1) an Electric Distributor that controls a Public Distribution Microgrid, (2) a Member that an Electric Distributor has designated to control a Public Distribution Microgrid on an Electric Distributor’s behalf, or (3) a generation and transmission cooperative or a joint municipal agency that is an Electric Distributor and that has a member that controls a Public Distribution Microgrid. Control of a Public Distribution Microgrid means control of switchgear, relays, microgrid controller and other equipment required to island generation and load in a Public Distribution Microgrid. ~~A PDM Operator shall obtain mutual consent from all affected Electric Distributors and the applicable fully metered Electric Distribution Company regarding whether or not the PDM load is reported to PJM as wholesale load when the PDM is islanded.~~

Public Distribution Microgrid Generator is any share of a generator in a Public Distribution Microgrid that is a PJM Generating Facility and that is capable of generating while both connected to and while islanded from the broader grid.



M-14D, Appendix B: Public Distribution Microgrid Business Rules

Telemetry

A Public Distribution Microgrid Operator shall ~~provide to ensure that the~~ Public Distribution Microgrid Generator ~~has access to the real-time status of any switching and/or relay that indicates the~~ islanded status of the Public Distribution Microgrid.

A Public Distribution Microgrid Generator shall meet existing telemetry requirements for all PJM generators as specified in Manual 1: Control Center Requirements and Section 4.2.2 of Manual 14-D, Generator Operational Requirements. In addition, in order for PJM to know whether the Public Distribution Microgrid Generator is islanded or not, it shall provide ~~that its~~ real-time islanded status to PJM ~~as well~~.

Operations

For planned Public Distribution Microgrids, ~~the~~ Public Distribution Microgrid Operator shall, in accordance with PJM Operating Agreement Section 11.3.3, provide PJM, the Transmission Owner, and the distribution utility (if applicable) with the relevant details of the operation of the mechanism(s) that are part of the microgrid control scheme that island and reconnect the Public Distribution Microgrid, such as criteria for ~~relay automatic~~ disconnection and reconnection.

A Public Distribution Microgrid Generator shall notify PJM of the start and end of planned and actual islanded conditions as soon as practicable. To facilitate this notification, the Public Distribution Microgrid Operator shall provide all necessary information to the Public Distribution Microgrid Generator operator on an ongoing basis. Such coordination is not required in the event that PJM requests that the Public Distribution Microgrid Generator run to support an islanding event related to NERC Bulk Electric System facilities or PJM Transmission Facilities. The Public Distribution Microgrid Generator shall meet all other existing notification requirements.



M-14D, Appendix B: Public Distribution Microgrid Business Rules

Reporting

When islanded, the Public Distribution Microgrid Generator should report a full outage in eDART. In GADS, if a Public Distribution Microgrid Generator's full ICAP MW is physically available and is only constrained because it is in island mode, no unplanned outage needs to be reported and the Microgrid Generator can be listed as fully available.

If the islanded Public Distribution Microgrid Generator is limited to less than its committed ICAP MW while serving load, due to reasons other than being constrained by the total load in the island, an unplanned outage should be reported in GADS.

The applicable fully metered Electric Distribution Company and the affected Electric Distributor(s) shall coordinate with the Public Distribution Microgrid Operator to determine whether the load is reported to PJM as wholesale load when the PDM is islanded.

If the ~~Electric Distribution Company (EDC) determines a~~ PDM load is reported to PJM as wholesale load when the PDM is islanded ~~(that is, the islanded load is reported to PJM as wholesale load), then:~~

- The applicable fully metered Electric Distribution Company~~EDC~~ should expect the PDM Generators to submit their islanded output as PJM supply. In this case, the islanded PDM Generators serve PJM load when islanded.
- To the extent the islanded PDM Generator is constrained in its output due to the islanded state, PJM will use reporting on islanding status to calculate a corresponding EFORD impact based on any reductions relative to committed ICAP MW due to reasons other than PJM dispatch or constraints on PJM Transmission Facilities.

If the ~~EDC determines a~~ PDM load is not reported to PJM as wholesale load when the PDM is islanded ~~(that is, the islanded load is not reported to PJM as PJM load), then:~~

- aAny islanded PDM Generators should also not report their output as PJM supply. In this case, the islanded PDM Generators do not serve PJM load when islanded.
- PJM will use reporting on islanding status to calculate an EFORD for such Public Distribution Microgrid Generators consistent with them being unavailable to serve PJM load when islanded.

M11, Section 2.3.3.4 Public Distribution Microgrid Generators

All existing Energy & Ancillary Services Market Business Rules apply to a Public Distribution Microgrid (PDM) Generator operating in grid-connected mode. Additional business rules apply to a Public Distribution Microgrid Generator operating in island mode:

- If ~~the an Electric Distribution Company determines a~~ Public Distribution Microgrid load is reported to PJM as wholesale load when the PDM is islanded ~~(that is, the islanded load is reported to PJM as wholesale load)~~, the corresponding Public Distribution Microgrid Generator(s) should update their availability Markets Gateway to Must Run for corresponding intervals in order to reflect the islanded condition.
- If ~~the an Electric Distribution Company determines a~~ Public Distribution Microgrid load is retail not reported to PJM as wholesale load when the PDM is islanded ~~(that is, the islanded load is not reported to PJM as wholesale load)~~, the corresponding Public Distribution Microgrid Generator(s) should make themselves unavailable for all PJM markets for the corresponding intervals to reflect the islanded condition.
- When the PDM is in island mode, an operator of a Public Distribution Microgrid Generator shall de-assign it from any existing Ancillary Services commitments (performance will be assessed as normal), and shall ensure it is not assigned for ancillary services for future intervals unless it is certain it will not be islanded in those intervals.

Definitions and additional business rules for Public Distribution Microgrids can be found in PJM Manual 14D, Appendix B: Public Distribution Microgrid Business Rules and PJM Manual 14D, Appendix C: Voluntary Guideline on Public Distribution Microgrid Operations.

For Public Distribution Microgrid Generators that are Generation Capacity Resources:

- If the ~~Electric Distribution Company determines a~~ Public Distribution Microgrid load is reported to PJM as wholesale load when the PDM is islanded ~~(that is, the islanded load is reported to PJM as wholesale load)~~, then any islanded generation MWh output that is settled through the PJM energy market counts towards Capacity Performance obligation as Actual Performance.
- If the ~~Electric Distribution Company determines a~~ Public Distribution Microgrid load is retail not reported to PJM as wholesale load when the PDM is islanded ~~(that is, the islanded load is not reported to PJM as wholesale load)~~, then any islanded Public Distribution Microgrid Generators should not report their islanded output as PJM supply. In this case, the islanded Public Distribution Microgrid Generator is not available to supply PJM load, and their Actual Performance is zero for the intervals in which the Public Distribution Microgrid is islanded.
- Whether a Public Distribution Microgrid load is or is not reported to PJM as wholesale load ~~or retail~~ when the PDM is islanded, the Expected Output Performance during a Performance Assessment Interval is what it would have been had the Public Distribution Microgrid Generator still been grid-connected.

Definitions and additional business rules for Public Distribution Microgrids can be found in PJM Manual 14D, Appendix B: Public Distribution Microgrid Business Rules and PJM Manual 14D, Appendix C: Voluntary Guideline on Public Distribution Microgrid Operations.