

# Virtual Combined Cycle Units in Regulation

Michael Olaleye  
Real-Time Market Operations  
Market Implementation Committee  
July 14, 2021

- Combine cycles can be modeled as a single market unit or split into multiple pseudo market units

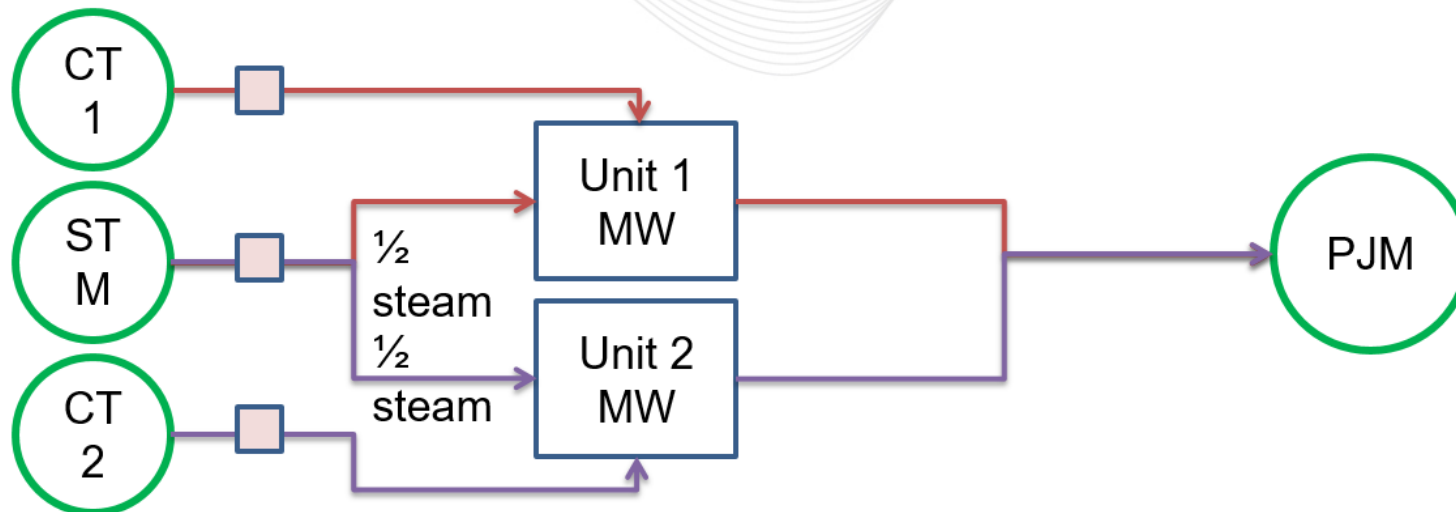

- Need to qualify each individual unit for regulation (M12.4.5)
- Once qualified - Units will be offered individually and dispatched individually based on market results

- Because the plant is modeled in multiple parts, there is a possibility for unbalanced or unequal awards to each “unit”





- Simplified RegLOC formula

$$|LMP - MC| * GENOFF$$

Where:

LMP – is the LMP at the resource bus;

MC – is the resource cost at the regulation set point;

GENOFF – is the MW deviation from the economic dispatch and the regulation set point

Note:

- In the clearing process, forecasted LMP is used
- In the pricing, Real-Time LMP is used
- RegLOC is further adjusted by:
  - Resource Historic Performance Score and
  - Resource Benefits Factor (if RegD)

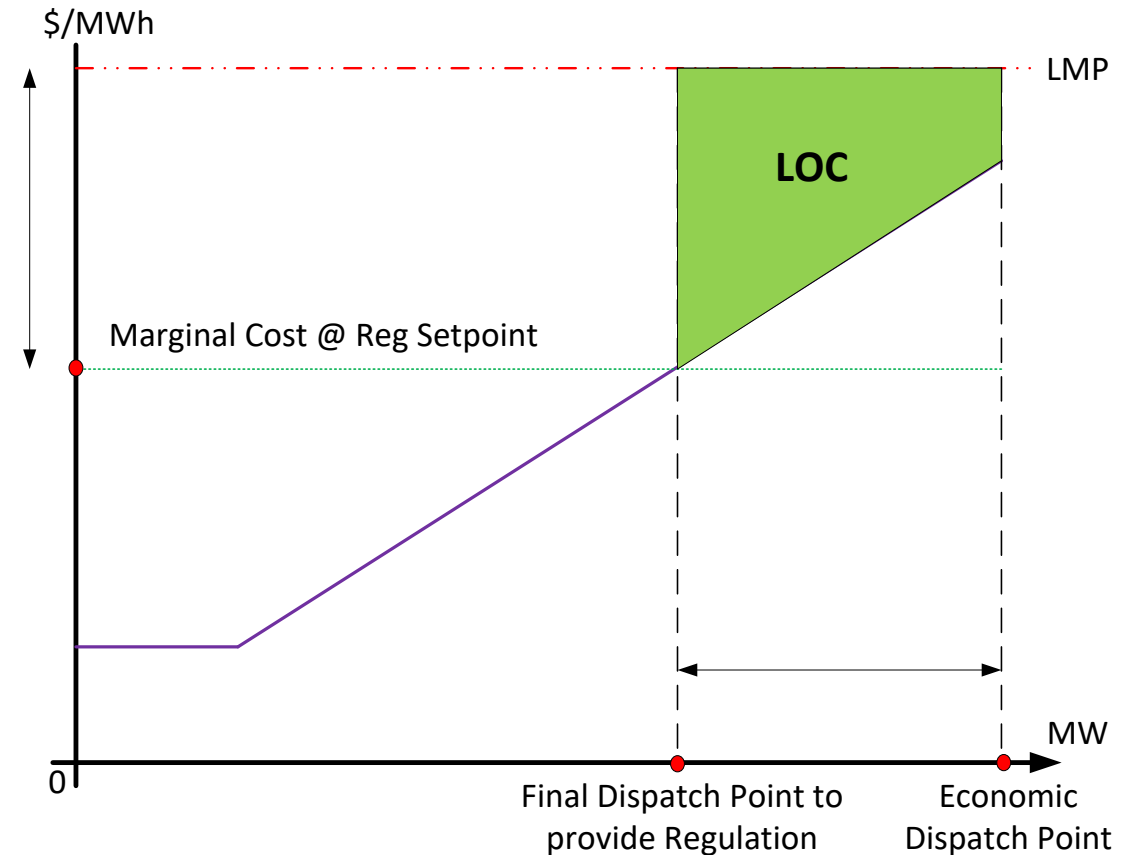

- Because of the potential differences in performance scores between the individual pseudo modeled units,
  - PJM suggests setting up and utilizing the performance group functionality (Manual 12, Section 4.5.7)
  - All resources within the group that have been awarded MWs for any one given hour will be awarded the same score
  - If each unit within the performance group has the same scores across hours
    - This will align the 100 hour rolling score (i.e. same 100 hours to average) that is used to calculate the adjusted regulation offers

MWs Cleared	Unit 1	Unit 2
HE1	10	0
HE2	10	10
HE3	10	5
HE4	10	10

Performance Group Scores	Unit 1	Unit 2
HE1	93%	N/A
HE2	95%	95%
HE3	92%	92%
HE4	91%	91%

## Key Takeaways:

- Same score for all resources in group given an award in one hour
- Differing assignments will not cause differing performance scores between units
- If units do not receive an assignment – they will not receive a score for that hour
  - This will alter the 100 hour rolling score between the units within the performance group (one unit with an extra score to average)
  - Ultimately causing misalignment of offers in the regulation market

- It is possible after each of these precautions that one pseudo unit will clear and other pseudo may not
  - Market Sellers should:
    - Contact PJM dispatch to decommit the resource for the hour. PJM practice is to decommit the regulation assignment for the committed pseudo unit.
- Another possibility is unbalanced awards across pseudo units.
  - Market Sellers should:
    - Contact PJM dispatch to lower the awards to be equal across all pseudo units or to a level that the plant can safely perform to.
- **Dispatch will not split awarded MWs across pseudo units.**





# Regulation Clearing Example

- Scenario 1

Requirement = 50 MW

Offer Prices assumed \$0

Resource	Energy MW	LOC = Rank	Reg MW Award
A	300	4	10
B	150	5	15
C	0	0	5
U1	215	7.2	0
U2	205	7	20

U1 did not get Reg award because the energy output caused a higher RegLOC

- Scenario 2

Requirement = 50 MW

All resources self-scheduled

Resource	Performance Score	Reg MW Award
A	0.921	10
B	0.955	15
C	0.968	5
U1	0.915	20
U2	0.908	0

U2 did not get Reg award because of its performance score

## Input:

Resource Energy  
Offers & Schedules

Resource Regulation  
Offers & Limits

...

### Regulation Clearing & Pricing

- (Historic) Performance Score
- Benefits Factor
- Lost Opportunity Cost
- Signal Mileage
- Joint Co-Optimization of Energy, Reserve, and Regulation
- Regulation Effective Requirement

## Output:

Resources with award  
(Least Cost Set)

Resources with no award  
(more expensive)

Market Clearing Prices

## Key Takeaways:

- Virtual CC units may not clear equally if their parameters are not exactly the same;
- The software clears the least cost set to satisfy the regulation requirement MW;
- Splitting award with another unit that did not clear (out-of-market action) could potentially inflate the market clearing price. No award splitting.

Facilitator: Lisa Morelli,  
[Lisa.Morelli@pjm.com](mailto:Lisa.Morelli@pjm.com)

Secretary: Nick DiSciullo,  
[Nicholas.DiSciullo@pjm.com](mailto:Nicholas.DiSciullo@pjm.com)

SME: Gabby Genuario,  
[Gabrielle.Genuario@pjm.com](mailto:Gabrielle.Genuario@pjm.com)

SME/Presenter: Michael Olaleye,  
[Michael.Olaleye@pjm.com](mailto:Michael.Olaleye@pjm.com)

Performance Compliance Department,  
[PerfCompDept@pjm.com](mailto:PerfCompDept@pjm.com)

## Regulation for Virtual Units



## Member Hotline

(610) 666 – 8980

(866) 400 – 8980

[custsvc@pjm.com](mailto:custsvc@pjm.com)